









FITTING INSTRUCTIONS

SLIDE AND SCREW FIXING METHOD

-  50 dB
-  60 Min.
-  200.000 cicli
-  1,45 m³ / h / m - 25 Pa
- 
- 
- 
- 

1703

ACU

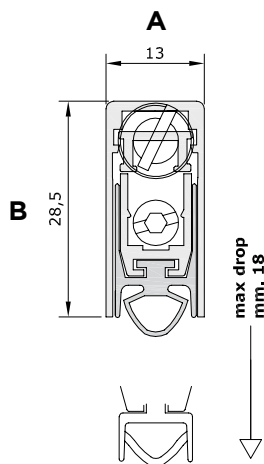

TOOLS
REQUIRED



STANDARD SIZES (mm)	430	530	630	730	830	930	1030	1130	1230	1330
Z (mm)	150	100	100	100	100	100	100	100	100	100

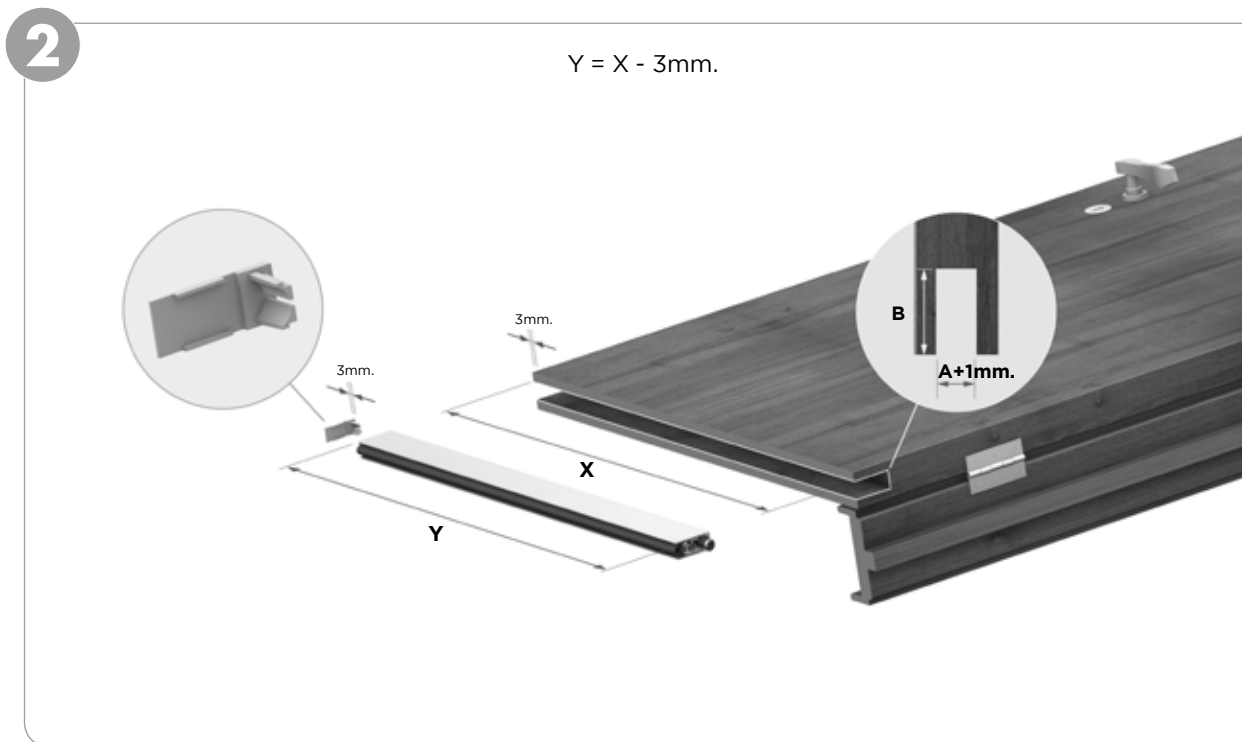
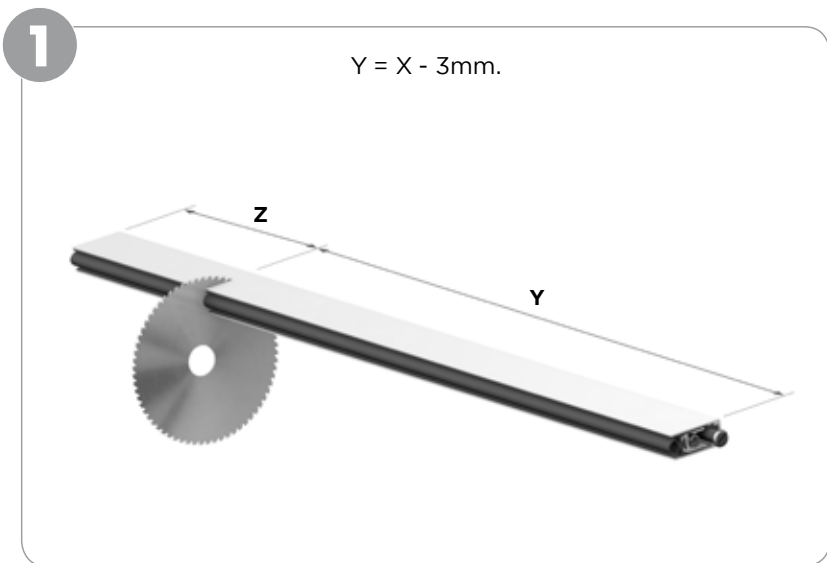

FITTING INSTRUCTIONS SLIDE AND SCREW FIXING METHOD

- 50 dB
- 60 Min.
- 200.000 cicli
- 1,45 m³ / h / m - 25 Pa



3



4.a

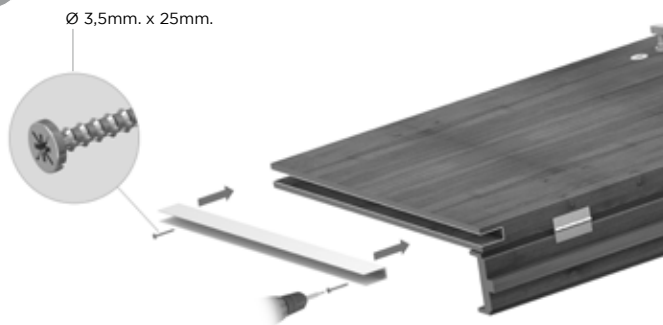

5.a

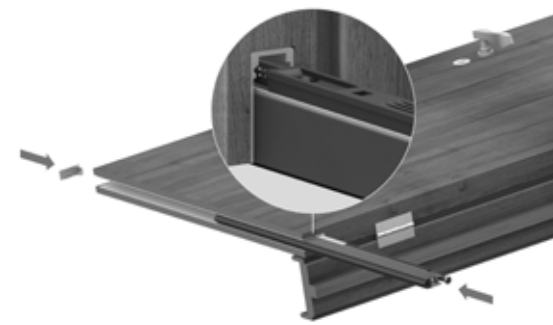

4.b

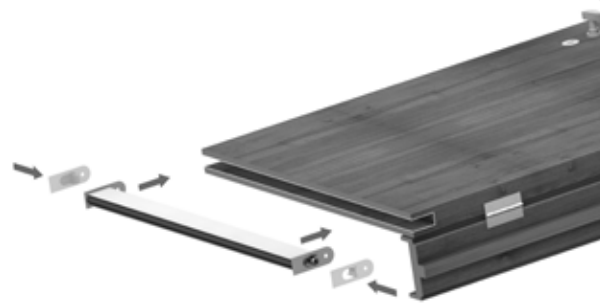

5.b

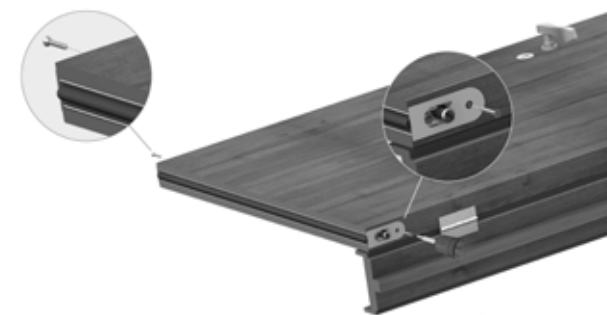

OPTIONAL
END-CLIP FIXING METHOD

6

